

Conceptpower DPA 500 100 - 500 kW

Technical Specifications



TABLE OF CONTENTS

- 1.1 CONCEPTPOWER DPA 500 - SYSTEM DESCRIPTION 3**
 - 1.1.1 True modularity up to 3 MW..... 3
 - 1.1.2 True parallel architecture 3
 - 1.1.3 Key Features of CONCEPTPOWER DPA 500..... 3
- 1.2 GENERAL CHARACTERISTICS..... 4**
- 1.3 INPUT CHARACTERISTICS 6**
- 1.4 OUTPUT CHARACTERISTICS 7**
- 1.5 BATTERY CHARACTERISTICS 8**
 - 1.5.1 Graph: AC / AC efficiency with linear load @ $\cos(\phi) = 1$ * 8
- 1.6 USER INTERFACE - COMMUNICATION 9**
 - 1.6.1 System Display 9
 - 1.6.2 DPA Display 10
 - 1.6.3 Mimic Diagram..... 10
- 1.7 CUSTOMER INTERFACES 10**
 - 1.7.1 Customer inputs dry ports: Terminal blocks X3 / 3-14..... 10
 - 1.7.2 Outputs dry ports: Terminal blocks X2 + X3 / 1-2..... 10
 - 1.7.3 Interlock castell function: Terminal block X1 10
- 1.8 OPTIONS 12**
- 1.9 ON REQUEST..... 12**
- 1.10 INSTALLATION PLANNING 12**
- 1.11 HEAT DISSIPATION..... 12**
- 1.12 SINGLE INPUT FEED – SEPARATE BATTERIES CONFIGURATION..... 13**
- 1.13 DUAL INPUT FEED – COMMON BATTERY CONFIGURATION 14**

1.1 CONCEPTPOWER DPA 500 - SYSTEM DESCRIPTION

ABB's Conceptpower DPA 500 is a high-power, modular and transformer-free UPS system for organizations who need zero downtime. The UPS is built using true online double conversion technology and provides low cost of ownership.

1.1.1 True modularity up to 3 MW

Now you can have a UPS size to exactly fit your needs: the Conceptpower DPA 500 is the only modular UPS on the market that can easily be scaled up to 3MW of clean, reliable power. This scalability means that there is no need to over-specify the original configuration as power modules can simply be added, as needed, in the future.

1.1.2 True parallel architecture

Reliability and availability are ensured by the Conceptpower DPA 500's proven Decentralized Parallel Architecture (DPA™). Each module contains all the hardware and software required for full system operation. They share no common components. Each UPS module has its own independent static bypass, rectifier, inverter, logic control, control panel, battery charger and batteries. With all the critical components duplicated and distributed between individual units, potential single points of failure are eliminated.

1.1.3 Key Features of CONCEPTPOWER DPA 500



- 100 kW rated power module
- 500 kW rated power in single frame
- Extended power range: from 100 kW to 3 MW
- Unity output power factor (kVA = kW)
- AC-AC efficiency up to 96 %
- Efficiency in eco-mode ≥ 99 %
- Online Swap Modularity (OSM)
- Online serviceability
- Top or bottom cable entry (standard)
- Built-in back-feed protection (standard)
- Graphical display on system level
- DPA displays in each module

This Technical Datasheet (TDS) provides all technical specification required by IEC 62040-3, providing mechanical, electrical and environmental characteristics. It can be used for tendering and end-user requirements. CONCEPTPOWER DPA 500 is designed to respond to the actual UPS standards which are:

- safety, IEC / EN 62040-1
- EMC, IEC / EN 62040-2
- performance, IEC / EN 62040-3

1.2 GENERAL CHARACTERISTICS

General characteristics - Frame	Values	Unit
Model: Conceptpower DPA 500		
		
Power, rated:		
apparent	500	kVA
active	500	kW
Power, range	100 - 3000	kW
UPS type: on-line, transformerfree, modular, decentralized parallel architecture		
Parallel capability: up to 6 frames		
Battery: not included		
Performance classification: VFI-SS-111		
Mechanical		
Dimensions (width x height x depth)	1580x1975x940	mm
Mass, approx. (500kW system, with 5 modules)	975	kg
Acoustic noise (acc. to IEC 62040-3)		
in normal mode (at <=25°C) at 100% / 50% Load	75 / 67	dBA
in battery mode (at <=25°C) at 100% / 50% Load	73 / 66	
Safety		
Access: operator/restricted		
Degree of protection against hazards and water ingress: IP 20		
Electromagnetic compatibility		
compliant		
Emission UPS Cat / Immunity UPS Cat	C3 / C3	
Environmental		
Storage temperature range	-25 - +70	°C
Operative temperature range	0 - +40	°C
Relative humidity range (non-condensing)	≤ 95	%
Max. altitude without de-rating	1000	m
Additional and usual information		
Connection: 5 wires, 3 phase + N + PE		
Cable entry: top or bottom		
Accessibility: frontal only		
Color: Graphite Grey (RAL 7024)		
Color code: Pulverlacke N°4222903402		

General characteristics - Module	Values	Unit
Model: Conceptpower DPA 500		
		
		
Power, rated:		
apparent	100	kVA
active	100	kW
UPS type: on-line, transformerfree, modular, decentralized parallel architecture		
Parallel capability: up to 6 frames		
Battery: not included		
Performance classification: VFI-SS-111		
Mechanical		
Dimensions (width x height x depth):		
active sub-module / passive sub-module	710x178x750	mm
Mass, approx.:		
active sub-module / passive sub-module	55 / 54	kg
Additional and usual information		
Back feed protection: included		
Color: Black (RAL 9005)		

1.3 INPUT CHARACTERISTICS

Input characteristics	UPS frame values	UPS module values	Unit
Power, rated:	500	100	kW
Voltage (steady-state, r.m.s), rated:		3x380/220V+N 3x400/230V+N 3x415/240V+N	VAC
tolerance, referred to 400/230V		-10 / +15 at <100% load -20 / +15 at <80% load, -30 / +15 at <60% load	%
Frequency, rated		50	Hz
tolerance, referred to 50Hz		-30/+40	%
Current (r.m.s), rated (with battery charged and input 400/230V)	760	152	A
maximum (with battery charging and input 400/230V)	835	167	A
total harmonic distortion (THDi)		< 3.5	%
in-rush current		< 100% of rated current	%
Power factor		0.99 @ 100% load	
Rated short-time withstand current (I_{cw})	25 for 1 s	-	kA, s
AC power distribution system: TN-S, TN-C, TN-C-S, TT note: in static bypass mode or eco-mode TN-C and TN-C-S can cause PE current to rise above 5% of phase currents.			
phases required		3	
neutral required		yes	
Additional and usual information			
Connection: 5 wires, 3 phase + N + PE			
Cable entry: top or bottom			
Accessibility: frontal			
Walk In/Soft Start: yes			
Back feed protection: yes			

1.4 OUTPUT CHARACTERISTICS

Output characteristics	UPS frame values	UPS module values	Unit
Power, rated:	500	100	kW
AC power distribution system: TN-S, TN-C, TN-C-S, TT			
available phases		3	
neutral available		yes	
Voltage (steady state, r.m.s.), rated:		3x380/220V+N 3x400/230V+N 3x415/240V+N	VAC
variation in normal mode / battery mode		$\pm 1.5 / \pm 1.5$	%
Total harmonic distortion (THDu), 100% load, normal mode:			
linear		< 2.0	%
non-linear (according to IEC 62040-3)		< 4.0	
Total harmonic distortion, 100 % load, battery mode:			
linear		< 2.0	%
non-linear (according to IEC 62040-3)		< 4.0	
Voltage unbalance and phase displacement, 100 % load unbalance		0	°
Voltage transient and recovery time, 100% step load:			
linear		± 4	%
non-linear (according to IEC 62040-3)		± 4	%
transfer normal mode --> battery mode		0	%
Frequency (steady-state), rated:		50/60	Hz
variation in normal mode (frq. Synchronized with mains)		$\pm 2 / \pm 4$	%
variation in battery mode (free-running)		± 0.1	
Max synch phase error (referred to a 360° cycle)		<2	°
Max slew-rate		1	Hz/s
Nominal current (In), r.m.s. rated:	725	145	A
overload on inverter		0.5 @ 150% load, 5 @ 125% load, 20 @ 110% load	min
fault clearing capability normal mode and battery mode for 100ms	1711 (2.36xIn)	348 (2.4xIn)	A
Load power factor, rated		1	
displacement (permissible lead-lag range)		(all range) 0	%, s
AC / AC efficiency in normal mode, linear load:			
100% load		95.6	%
75% load		96.0	
50% load		96.1	
25% load		95.8	
Eco-mode efficiency, linear load		≥ 99	%
Crest – Factor (Load supported)		3:1	
Static bypass			
Type: automatic, static switch in each module			
transfer time: inverter → bypass / bypass → inverter / in eco-mode		<1 / <5 / <6	ms
rated current	800	160	A
fault clearing capability (bypass mode) for 20 ms	10xIn	10xIn	A
overload current on bypass mode (< 25°C)		continuously @ 110% load	min
Maintenance bypass: optional on the frame			
Bypass protection fuse or circuit breaker rating		5x160	A, gL fuse

1.5 BATTERY CHARACTERISTICS

Battery characteristics	Values	Unit
Technology: VRLA, vented lead-acid, NiCd		
Number of 12 V blocks (even and odd)	42 - 48 ¹⁾	
Number of 1.2 V NiCd cells (even and odd)	420 - 480 ¹⁾	
Battery charger: decentralized, each module has its own charger		
Max. current charger capability	60	A
Max. power charger capability	30	kW
Floating voltage (VRLA / NiCd)	2.25 / 1.40	VDC
End of discharge voltage (VRLA / NiCd)	1.65 / 1.05	
r.m.s. ripple current (percentage of the battery capacity)	2	%
Temperature compensation: optional		
Battery test: automatic and periodic battery test (selectable)		

1) IMPORTANT NOTES:

- for short autonomies (< 20 minutes) the UPS supports 40 - 50 12V blocks
- the range 42 - 48 supports any autonomy.
- at output voltage 415/240VAC the minimum 12V block is 42.

1.5.1 Graph: AC / AC efficiency with linear load @ cos(phi) 1 *

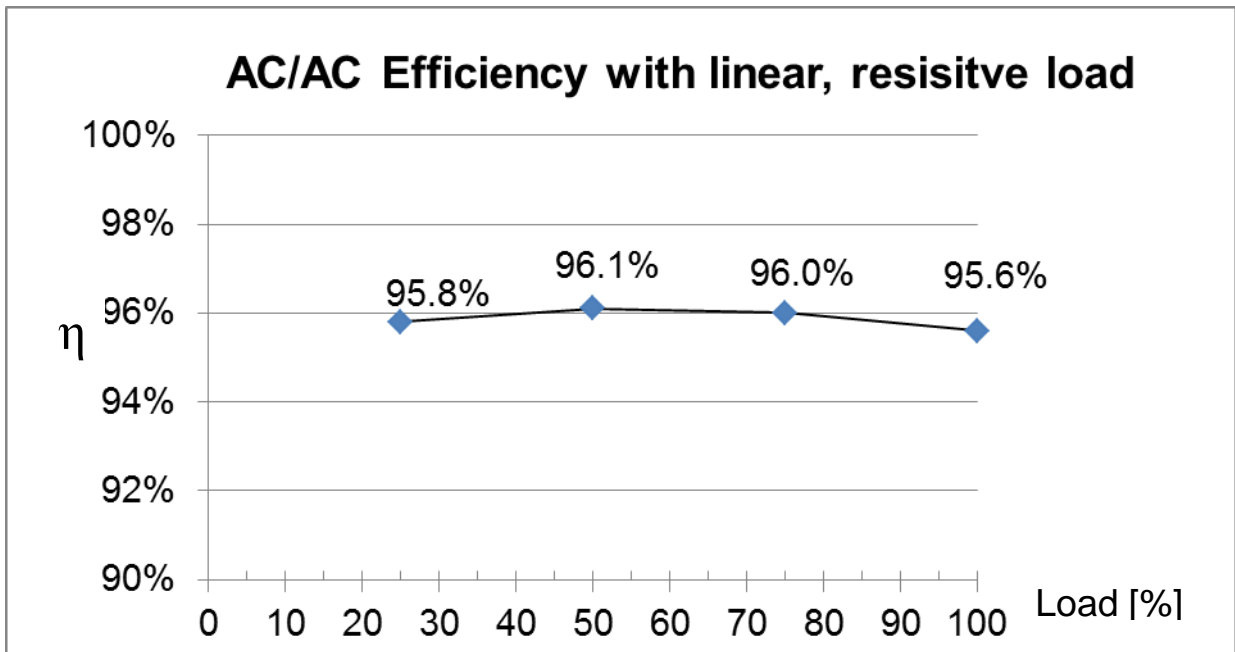

* tolerance of ± 0.2% applies on all figures.

1.6 USER INTERFACE - COMMUNICATION

System Display	7" touchscreen display (one per frame)	
DPA display (or module display)	2 x 20 character LCD display (one per module)	
MIMIC diagram	LED-indicator, 5x green/red LEDs (one per module)	
RS232 on Sub-D9 port RS232 on USB port	For monitoring and integration in network management	
Customer Interfaces : Inputs DRY PORT	1 Remote Shut down [EMERGENCY OFF (Normally closed)] 1 GEN-ON (Normally open) 1 Programmable Customer's Inputs (Normally open) 1 Temp. Sensor for Battery Control	
Customer Interfaces : Outputs DRY PORT	6 voltage free contacts For remote signaling and automatic computer shutdown	
RS485 on RJ45 port	Remote monitoring system with remote panel (graphical display)	Optional
RS485 on RJ45 port	For multidrop purpose	Optional
Slot for SNMP	SNMP card For monitoring and integration in network management	Optional

1.6.1 System Display

The user-friendly touchscreen graphical display on the system level offers the opportunity of directly monitoring the system status as well as the status of each individual module. The graphical display additionally provides all the measurements (module and system level) and the user is able to transfer from INVERTER to BYPASS and vice-versa. All other commands must be performed on the DPA display. With both displays in place (module and system level), the UPS offers full user friendliness without making compromises on robustness.

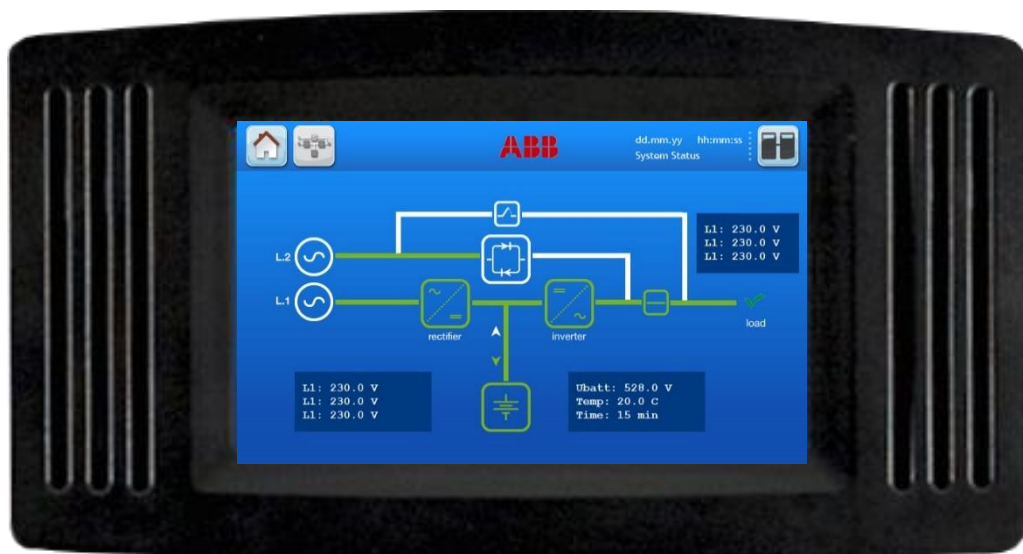

1.6.2 DPA Display

The 2 x 20 character LCD simplifies the communication with the UPS. The menu driven LCD enables the access to the EVENT REGISTER, or to monitor the input and output U, I, f, P, Autonomy Time and other Measurement's, to perform commands like start-up and shut-down of INVERTER or load transfer from INVERTER to BYPASS and vice-versa and finally it serves for the DIAGNOSIS (SERVICE MODE) for adjustments and testing (for more details see the USER MANUAL of Conceptpower DPA 500).

1.6.3 Mimic Diagram

The mimic diagram serves to give the general status of the UPS. The LED-indicators show the power flow status and in the event of mains failure or load transfer from inverter to bypass and vice-versa the corresponding LED-indicators will change colour from green (normal) to red (warning). The LED's LINE 1 (rectifier) and LINE 2 (bypass) indicate the availability of the mains power supply. The LED's INVERTER and BYPASS if green indicate which of the two are supplying power to the critical load. When the LED-indicator BATTERY is lit it means that the battery due to mains failure is supplying the load. The LED-indicator ALARM is a visual indication of any internal or external alarm condition. At the same time the audible alarm will be activated.

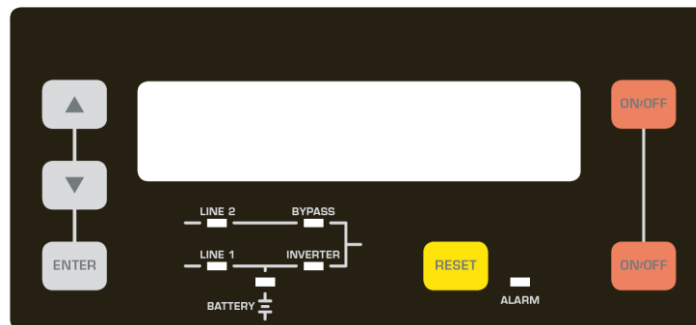

1.7 CUSTOMER INTERFACES

1.7.1 Customer inputs dry ports: Terminal blocks X3 / 3-14

Connection of Remote Shut down facilities, Generator Operation, Customers specials (see UM Section 9 / OPTIONS)

1.7.2 Outputs dry ports: Terminal blocks X2 + X3 / 1-2

Provision of signals for the automatic and orderly shutdown of servers, AS400 or Automation building systems

1.7.3 Interlock castell function: Terminal block X1

This function allows a secure transfer from inverter (normal operation) to external maintenance bypass and vice-versa. During normal operation the external bypass is locked in position OFF. Only when the UPS is/are transferred to static bypass mode, the lock on the external bypass is released and it possible to switch to position ON. The transfer from maintenance bypass back to normal operation happens exactly the other way around. The release signal is 230VAC when the maintenance bypass is free and 0V when locked.

All Terminals X1-X3 can hold Cable from 0.2mm² – 1.5mm²
 X1 is a 230VAC output which allows to interface with a interlock system.
 All X2 are potential free contacts and are rated: Max 250Vac/8A; 30Vdc/8A; 220Vdc/0.12A
 All X3 (except X3 5/6 which is a 12VDC source) are inputs, cable max. R 50Ω at 20mA

Block	Terminal	Contact	Signal	On Display	Function
X3	X3 / 14	GND	GND	-	Battery Temperature (only the optional battery sensor from ABB is compatible)
	X3 / 13	IN	+3.3VDC	-	
	X3 / 12	GND	GND	GENERATOR_ OPER_ON	Generator Operation (N.O.) Min. contact load 12V / 1mA
	X3 / 11	IN	+12Vdc		
	X3 / 10	GND	GND	PARRALEL_SW_OPEN PARRALEL_SW_CLOSE	External Output Breaker (N.O.) Min. contact load 12V / 20mA.
	X3 / 9	IN	+12Vdc		
	X3 / 8	GND	GND	EXT_MAN_BYP	External Manual Bypass (Ext. IA1) (N.O.) Min. contact load 20mA
	X3 / 7	IN	+12Vdc		
	X3 / 6		+12Vdc	-	+ 12 VDC source (UPS protected) (Max. 200mA)
	X3 / 5		GND	-	
	X3 / 4	GND	GND	REMOTE_ SHUTDOWN-	RSD (Remote Shut down) Default setting: disabled. Possibility to enable and set NO or NC via NewSet.
	X3 / 3	IN	+12Vdc		
	X3 / 2		-	REMOTE_ SHUTDOWN-	RSD (Remote Shut down) for external switch Max. 250Vac/8A ;30Vdc/8A ;110Vdc/0.3A ;220Vdc/0.12A
X3 / 1	-				
X2	X2 / 18	C	-	-	Common
	X2 / 17	NC	-	-	Relais AUX (function on request, to be defined)
	X2 / 16	NO	-	-	
	X2 / 15	C		COMMON_ALARM	Common
	X2 / 14	NC	ALARM		No Alarm Condition
	X2 / 13	NO			Common Alarm (System)
	X2 / 12	C		LOAD_ON_MAINS	Common
	X2 / 11	NC	Message		No Load on Bypass
	X2 / 10	NO			Load On Bypass (Mains)
	X2 / 9	C		BATT_LOW	Common
	X2 / 8	NC	ALARM		Battery Ok
	X2 / 7	NO			Battery Low
	X2 / 6	C		LOAD_ON_INV	Common
	X2 / 5	NC	Message		No Load on Inverter
	X2 / 4	NO			Load on Inverter
	X2 / 3	C		MAINS_OK	Common
	X2 / 2	NC	ALARM		Mains Failure
	X2 / 1	NO			Mains Present
X1	X1 / 2		-	EXT_MAN_BYP	Interlock Function (Ext Manual Bypass) 230Vac / 2AT

Customer Interface Conceptpower DPA 500

1.8 OPTIONS

- Maintenance bypass
- SNMP cards
- Battery Cabinet
- Parallel KIT for paralleling multiple frames
- Wooden box
- Temp. sensor for battery temp. control

1.9 ON REQUEST

- INPUT / OUTPUT transformers for galvanic isolation or special voltages
- Bypass transformer
- IP 21

1.10 INSTALLATION PLANNING

Clearances needed to allow proper airflow on the UPS system and to allow door opening.

Minimum clearances for single UPS				
UPS Model	A ₁ (mm)	B ₁ (mm)	C (°)	D (mm)
DPA 500	300	1000	115°	400

Minimum clearances for UPS + other cabinets in row				
UPS Model	A ₂ (mm)	B ₂ (mm)	C (°)	D (mm)
DPA 500	300	1000	115°	400

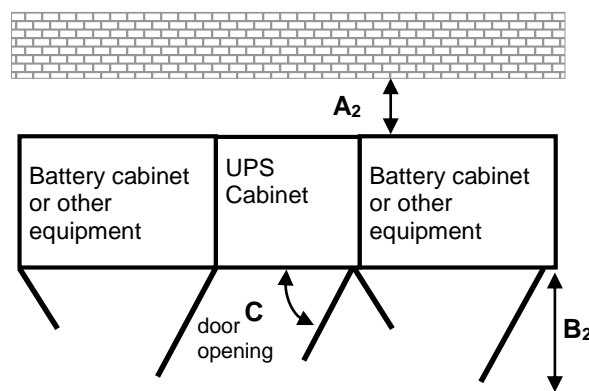
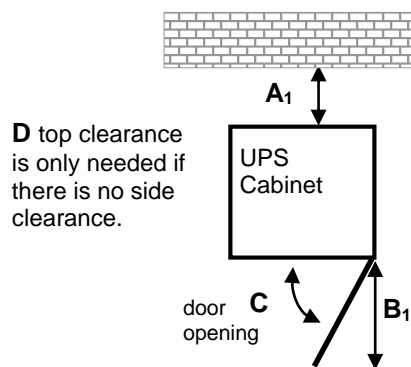

Top view and indication of the minimum clearances for single UPS.

Top view and indication of the minimum clearances for UPS + other cabinets in row .

1.11 HEAT DISSIPATION

Module quantities		1	2	3	4	5
UPS power rating	kW	100	200	300	400	500
Heat Dissipation with 100% linear load	W	4500	9000	13500	18000	22500
	BTU	15359	30717	46076	61434	76793
Heat Dissipation with 100% non-lin.load (acc. to IEC 62040-3)	W	5710	11420	17130	22840	28550
	BTU	19488	38976	58465	77953	97441
Airflow (25° - 30°C) with 100% non-lin. Load (acc. to IEC 62040-3)	m ³ /h	1200	2400	3600	4800	6000
Heat Dissipation without load	W	660	1320	1980	2640	3300

1.12 SINGLE INPUT FEED – SEPARATE BATTERIES CONFIGURATION

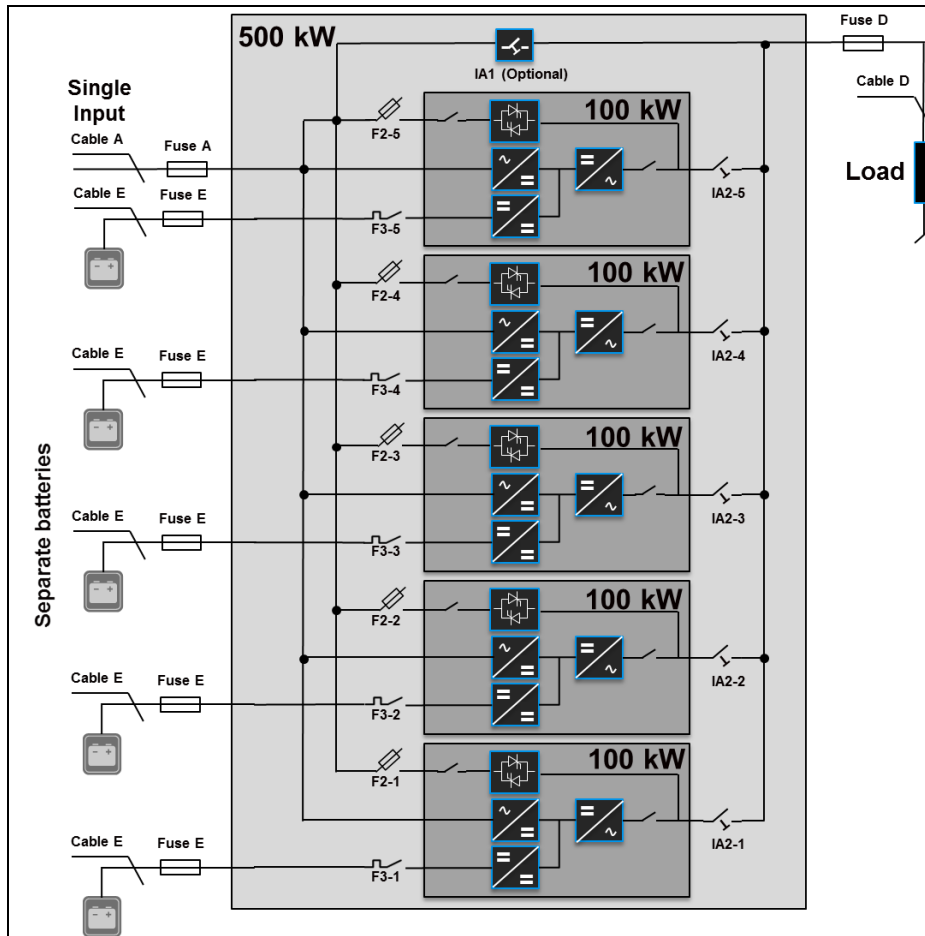

Figure 1: Block diagram of DPA 500 with single input feed and separate batteries configuration.

Table 1: Recommended AC wiring (copper wires) according to IEC 60950-1, recommended fuse ratings for slow line fuses (gL) or circuit breakers (CB), connection terminal size and max. tightening torque.

Rated power (kW)	Single input Max. rectifier input current with charging batt. 835A at 230V / 875A at 220V		Output Rated output current in normal conditions 725A at 230V / 758A at 220V	
	Fuse A Type: gL or CB (quantity x A)	Cable A (quantity x mm ²)	Fuse D Type: gL or CB (only needed in parallel system) (quantity x mm ²)	Cable D (quantity x mm ²)
500	3 x 1000A (3 pole, bolded N)	5x(2x240) 5x(3x120)	4 x 800A (4 pole)	5x(2x240) 5x(3x120)
All connection points are bus-bar, M12. Recommended tightening torque 42 Nm				

Table 2: Recommended DC wiring (copper wires) according to IEC 60950-1, recommended fuse ratings for fast acting fuses (gR) or circuit breakers (CB), connection terminal size and max. tightening torque.

Separate batteries		
Rated power (kW)	Fuse E Type: gR or CB (quantity x A)	Cable E (quantity x mm ²)
100 (one module)	2 x 250A (2 pole)	2x(1x120) with 40-45 12V battery blocks 2x(1x95) with 46-50 12V battery blocks
All connection points are bus-bar, M8. Recommended tightening torque 24 Nm		

1.13 DUAL INPUT FEED – COMMON BATTERY CONFIGURATION

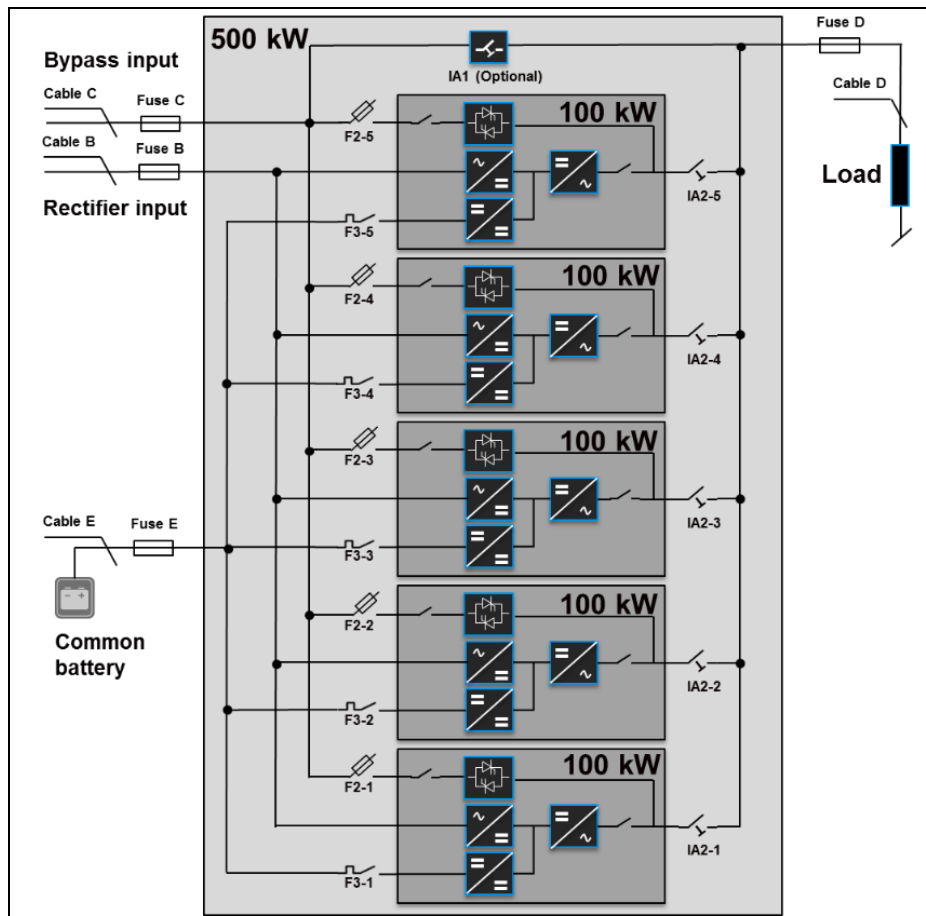

Figure 2: Block diagram of DPA 500 with dual input feed and common battery configuration.

Table 3: Recommended AC wiring (copper wires) according to IEC 60950-1, recommended fuse ratings for slow line fuses (gL) or circuit breakers (CB), connection terminal size and max. tightening torque.

Rated power (kW)	Rectifier input Max. rectifier input current with battery charging 835A at 230V / 875A at 220V		Bypass input Max. bypass input current 732A at 230V / 765A at 220V		Output Rated output current in normal conditions 725A at 230V / 758A at 220V	
	Fuse B Type: gL or CB (quantity x A)	Cable B (quantity x mm ²)	Fuse C Type: gL or CB (quantity x A)	Cable B (quantity x mm ²)	Fuse D Type: gL or CB (only needed in parallel system) (quantity x mm ²)	Cable D (quantity x mm ²)
500	3 x 1000A (3 pole, bolded N)	5x(2x240) 5x(3x120)	3 x 800A (3 pole, bolded N)	5x(2x240) 5x(3x120)	4 x 800A (4 pole)	5x(2x240) 5x(3x120)
All connection points are bus-bar, M12. Recommended tightening torque 42 Nm						

Table 4: Recommended DC wiring (copper wires) according to IEC 60950-1, recommended fuse ratings for fast acting fuses (gR) or circuit breakers (CB), connection terminal size and max. tightening torque.

Common battery		
Rated power (kW)	Fuse E Type: gR or CB (quantity x A)	Cable E (quantity x mm ²)
500	2x1250A (2 pole)	2x(3x240) 2x(4x150)
All connection points are bus-bar, M12. Recommended tightening torque 42 Nm		